

DEVELOPING AN INTEGRATED MODEL-BASED ON INTERNET OF THINGS (IoT) FOR A SMART SOLUTION TO SWIFTLY FIND PARKING AND OPTIMIZING OF PARKING LOTS

Gitesh Budhiraja

ABSTRACT

To detail and mimic a useful methodology for a nice parking spot and vehicle security utilizing the Internet of Things like the two of them are of fundamental significance in the current situation. Web of Things assumes a crucial job where everything is associated with all the fixings. Flex sensors, switch, RFID and other stuff have been utilized to beat the issue of the vehicle leaving. As of now, there have been beginning phase contemplates and has thought of model which will help client or drivers in finding the accessible parking spot with the assistance of IoT. Discoveries: Since adequate of related examinations have been as of now done; however coordinating some new highlights can positively prepare of leaving the executives as well as in creating the vehicle savvy. To stop office, we check whether the space is accessible, if thus, at that point, the entryway opens else not. Expense is charged on the temple premise. Since the car business and ICT industry amalgamate, the brilliant vehicle is a dominating issue. To make the car safe, we focus on unique mark sensor. The finger impression of each individual is remarkable. The ID of an approved client turns out to be increasingly reliable. With the end goal of vehicle security, we devise a unique mark based model alongside GPS and GSM. The prime focal point of the above model is to address gridlock, vehicle wellbeing, and its present area. We moreover guarantee using sensors joined inside that the driver isn't stoned, and the two people sitting on the primary line are tied up with seat strap. The best bit of this model is that it has been made using RFID and IOT contraption, for instance, Arduino UNO, GPS, GSM and vibration motor. It not simply overhauls correspondence between at any rate two related devices yet also keeps up the straightforwardness between them. All these can be refined at more affordable rates.

1. INTRODUCTION

In the flow situation, because of expansion in rush hour gridlock, adequate of drivers meander around looking for suitable parking spot. This makes gridlock as well as time squander. Imagine a scenario where a driver has advance data of accessible parking spot in the necessary objective area. So utilizing RFID, IOT we can design and give the stopping space to the driver ahead of time. For shopping centres and air terminal, parking spots are so amazingly enormous that it is challenging to oversee it physically. In metropolitan territories like Bangalore, Delhi, Chennai, vehicle leaving has gotten an essential subject with the consistent expansion in check of vehicles. Exploration study shows 40% of vehicles remembering car and bicycle for this gridlock are merely looking for an excellent leaving zone. The study additionally includes that a standard seven and a large portion

of minutes is expected to discover a space for stopping. An examination says that 75% of gadgets in INDIA will be associated with the web by year's end of 2018.

Current vehicle theft can't be nearly overlooked. It is expanding step by step. Any individual with an imitation of unique key can begin the vehicle. The vehicle will light regardless of the client. The client may drop the pass or fail to remember the key. It just adds disappointment. Seeing the focal issue that anyone can start the vehicle and drive away, we coin a model that fuses ARDUINO, special imprint sensor, vibration motor, GPS, and GSM. Much equivalent to PDAs with thumb impression, the particular imprint scanner can be used to light the vehicle. At the point when the customer has enrolled his thumb impression, the individual being referred to can use the vehicle. The vibration motor is to impersonate the engine of a vehicle. Moreover, we can similarly add different customers with various fingers. One the customer start his bike, he will likewise get message notice over his adaptable selected number close by the current region. The region joins Longitude and degree. Since different people can be enrolled, it makes it straightforward for a family having an ordinary vehicle among them. The motivation behind using biometrics is that chances of getting into politeness are inconsequential. At whatever point a customer performs biometric affirmation, the sensor snaps a photo of a thumb and choose the edges and valley. It by then facilitates the model with the as of late sifted pictures.

- Difficult to counterfeit.
- Nobody can figure the unique mark only like a secret word.
- No one replaces or take one's unique mark.
- No compelling reason to recollect that anything.

Finding the robbery vehicle is likewise a genuine concern. On the off chance that the shade of the car and number plate is transformed, it turns out to be more challenging for police to find the criminals. RFID innovation can be utilized to figure out this issue. RFID represents Radio Frequency Identification. Since the name itself recommends, it uses radio waves to perceive the things. These RFID can be fitted wherever in the vehicle and be orchestrated with any extent of repeat. Utilizing this RFID, we can follow the vehicle nuances and its certified owner.

2. LITERATURE SURVEY

"IoT based model for vehicle Parking Management System for Smart Cities" has proposed a structure for vehicle parking¹. In this paper, 4 modules are depicted, for example, book vehicle space web based utilizing any android application or online interface. Second, vehicle entrance. On the off chance that the space is accessible, at that point the door will open else not. Third, it additionally checks for taken or burglary vehicle utilizing RFID label fitted inside the vehicle. Fourth, on leave entryway expense will be charged dependent on various hours. These numerous

components altogether contribute towards efficient, power and superfluous traffic. "Minimization of Cruising for vehicle Parking" have executed PMMS (Parking checking and the board system)². In this paper, information is gathered with respect to accessible opening and give these subtleties to the end client of PMMS's application. Data is additionally assembled from vehicle client, their cell phones, and the leaving controller. PMMS has 4 distinct parts - 2 versatile application, worker, and information base. The versatile application goes about as an interface between the client and the information base. Since there are two kinds of clients - driver and stopping auditor so there exist 2 applications. The data set holds the data of accessible spaces.

"Programmed vehicle Parking Management System and Fee Collection Based on Number Plate Recognition" have actualized a calculation to leave vehicle naturally and assortment of the fee³. In this miniature regulator is pre-modified so that there is no prerequisite of human mediation. OCR is utilized to distinguish and remove the subtleties from number plate. In addition, it additionally directs the client towards his stopping space. At leave entryway, money should be paid. It considers no. of hours vehicle was left by considering section and leave time, the sum every hour, money paid and change. In the event that the client pays 10rs however they the expense sum was 7, at that point 3 Rs change must be rewarded the client. "An Intelligent Parking opening Management System" have actualized valet for savvy stopping at a low cost⁴. Fluffy rationale has been utilized for the above reason. The vehicle will be given 2 modules - One is IR sensor and other is the microcontroller. IR sensor will identify any snag impediment coming up in front with the goal that client won't hit his vehicle. The IR sensor on the distinguishing proof of obstruction at certain distance begins vibrating. Microcontroller will screen the stopping space intently and offer the fundamental rules to the client. It is independent stopping valet with negligible expense as there is no human association in this.

"A SMS Based Parking Reservation System", structure is proposed and executed for keen stopping utilizing text message⁵. In this paper, the client needs to initially get register with MCU specialist organizations. At the point when the client needs an opening, he/she communicates something specific mentioning for the space. GPS module joined with Arduino checks if the message is validated. On the off chance that not, at that point no answer is offered in return. In the event that the message is discovered valid, at that point MCU with the assistance of WSN communicates something specific that incorporates stopping space number and a password. The client should enter the password at the passageway and exit of the stopping territory. Upon leave, the all out charge is shown on the LED screen.

"Vehicle Safety System Enhancements utilizing the Internet of Things (IoT)" have actualized a structure for individuals wellbeing who is inside the vehicle. The system begins with liquor detection⁶. On the off chance that the driver is calm, at that point vehicle touches off else sit tight for 5 min. In the event that the liquor is detected during driving, at that point it shows a message and vehicle stops. The subsequent structure is characterized for others sitting close to the driver. IR sensor is fitted close to situate clasp. On the off chance that the two clasps are ON, at that point motor lights else not. In the event that if the vehicle meets with a mishap, ARM sensor detects the vehicle tilt and utilizing GPS and GSM sends the message to the closest police headquarters and Ambulance alongside the area. "A Security and Safety estimates based IoT Framework - installed bicycles" have proposed some improved arrangements over existing structure to limit bicycle and vehicle head-on collision⁷. The IoT based structure is coordinated into bicycle and vehicle so they can recognize MDS and CPD. Misconduct Detection Scheme gives security mindfulness by detecting vehicle's portability design dependent on mischief identification. Crash Prediction and Detection conspire (CPD) continues checking driver's expected conduct. Both the systems are an endeavor to limit the street mishaps.

"Vehicle Alert and Collision Prevention System utilizing Microcontroller" have proposed an equipment that incorporates one microcontroller, vibration sensor, GPS, EEPROM, and keypad⁸. If there should arise an occurrence of a mishap, an alarm message is sent utilizing GSM module to the individuals whose numbers is put away in EEPROM utilizing keypad. The vibration sensor is answerable for the discovery of a mishap. The vibration sensor is associated with miniature regulator utilizing MCP. MCP is answerable for changing over the simple sign into computerized signal giving an advanced yield to the miniature regulator. Furthermore, one LCD is likewise joined that will show all the activity occurring. "An Intelligent System for Accident Detection and sending Notification" has proposed a structure in which utilizing flex accelerometer sensor; mishap can be effectively detected⁹. Flex sensor is fundamentally protected innovation that distinguishes the mishap precisely. The system additionally incorporates a continuous camera alongside GPS and GSM module. The sole reason for this structure is to give assistance to individuals struck inside till the time emergency vehicle or police show up. GPS and GSM are utilized to send the alarm message to police and clinic. A camera fitted inside will show the current state of individuals stuck inside. "Remote system for Vehicle Accident Detection utilizing Accelerometer sensor and Reporting with the assistance of GPS" has proposed a structure utilizing microcontrollers to limit passing rates¹⁰. The system incorporates Microcontroller, GPS, GSM, EEPROM, gas sensor, temperature sensor, liquor sensor alongside memory card and LED. Accelerometer sensor is utilized to recognize the mishap. When the mishap has occurred, GPS will gather the current area of the mishap and with the assistance of GSM will advise the closest police headquarters. The gas sensor is utilized to detect whether is there any spillage of gas, the temperature sensor will detect the temperature inside the vehicle, liquor sensor is utilized to check whether the driver was calm

or high. All the subtleties will be put away in the memory card to recognize the reason for the mishap.

3. STRATEGY

The model we have begat is appeared in Figure 1. The accompanying model can be ordered into 4 sections:

- (I) Book on the web
- (ii) Entry of the Vehicle
- (iii) Vehicle Exit
- (iv) Management of Parking

The green concealing board is basically a raspberry pi which will be our regular laborer. It is a simple, splendid card assessed figuring model that can be associated with PC, PC or TV. The entire coding is done in python and set aside inside it

- Book Online: Since the drivers continue wandering around searching out for good leaving, utilizing this element they can book the space for vehicle leaving ahead of time. They simply need to introduce the application and can choose the empty opening. For this element, they don't need to pay anything ahead of time. Whenever booking is done, the worker will be refreshed appropriately. Figure 3 shows the away from of how the internet booking will be done progress of time. It is same as booking a seat in the café.

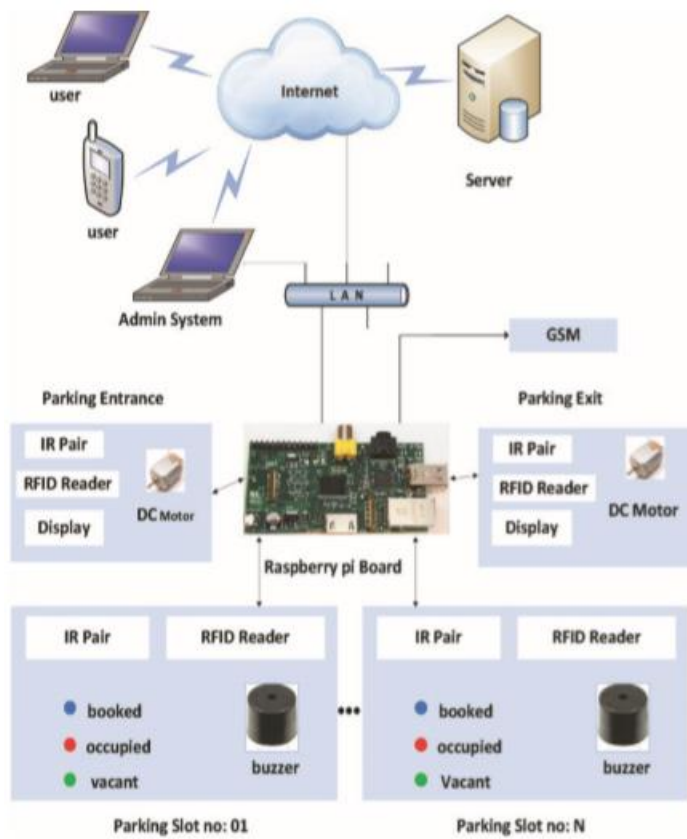

Figure 1. Prototype model for vehicle parking.

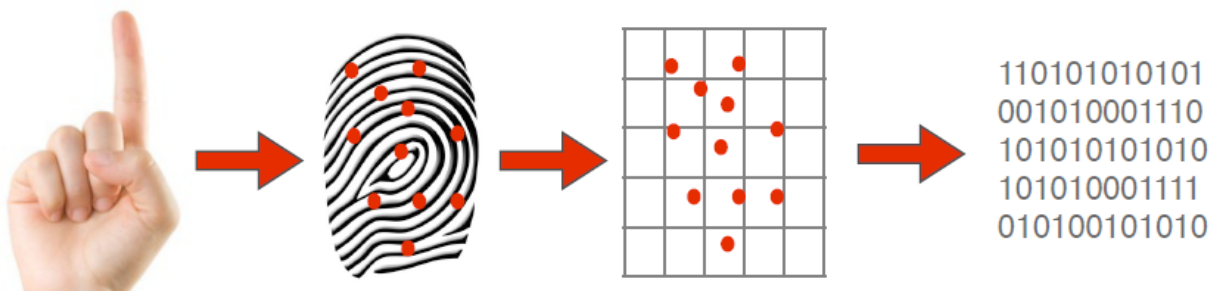

Figure 2. Mathematical Representation

• Vehicle Entry: On the passageway of the leaving entryway, we need to check if the vehicle entering is taken. On the off chance that it along these lines, at that point utilizing IPV6 convention, we will send an alarm message to the nearest police headquarters. Web utilizes a convention suite called TCP/IP convention. The motivation behind this convention is to recognize have utilizing the sensible location and to course information over organization layer of OSI model. When the

vehicle enters, utilizing RFID we cross-check the vehicle subtleties. In the event that no issues, at that point the opening will be apportioned dependent on accessibility. Figure 4 shows the away from of how vehicle passage will occur.

- **Parking Management:** Generally driver or client winds up in issue and stops the vehicle in some unacceptable space. Not just this, inept drivers may hit different vehicles also which causes disappointment among individuals. The issue can be handily figured out utilizing the accompanying calculation which is shown utilizing flowchart in Figure 5.

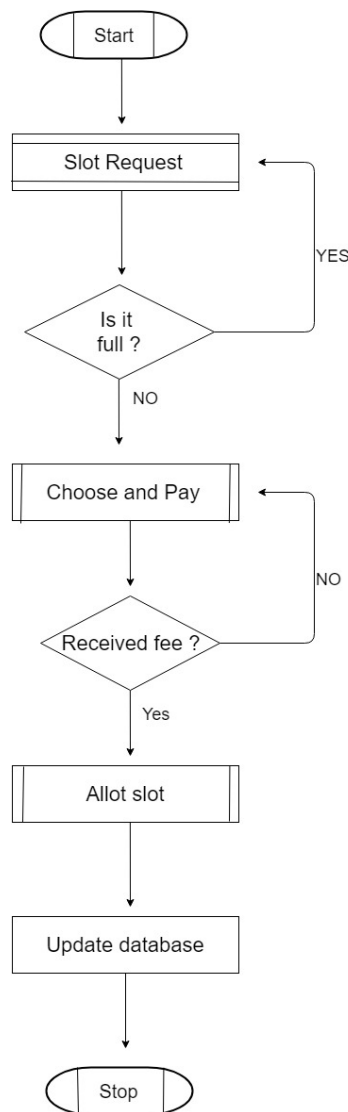

Figure 3. Flowchart for ‘Book Online’.

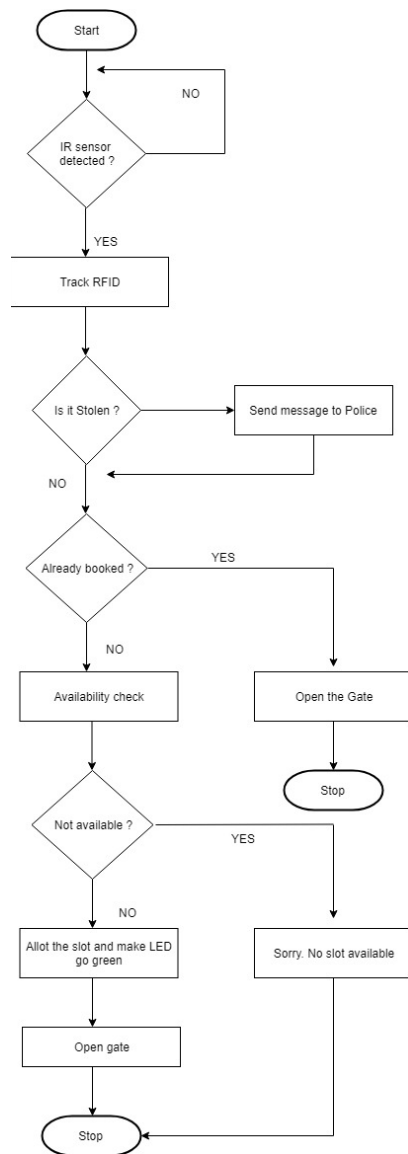

Figure 4. Flowchart for Vehicle Entry.

- **Exit of Vehicle:** Upon leaving the parking spot, the driver is needed to pay the charge which will be determined on time premise. Upon fruitful installment, that specific space will make empty again and the information base will be refreshed likewise so that next client can utilize the equivalent.

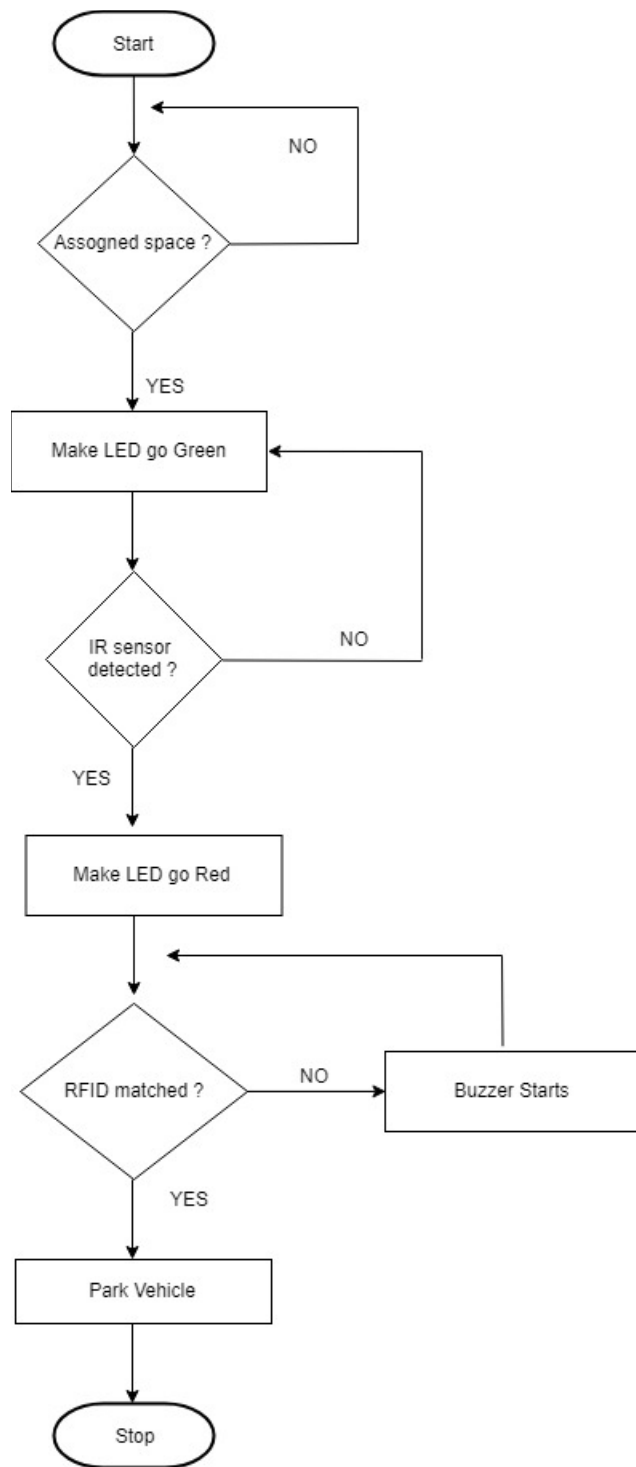

Figure 5. Parking Management Flowchart.

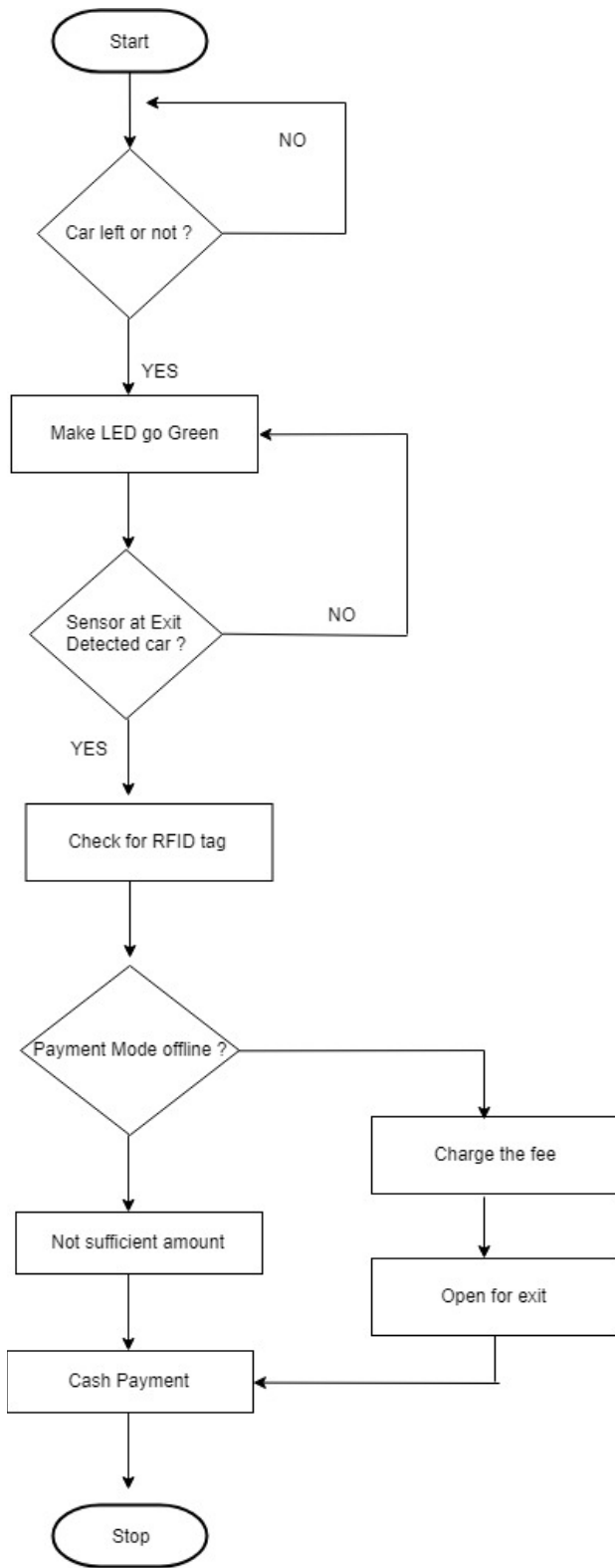

Figure 6. Flowchart of 'Exit of Vehicle'.

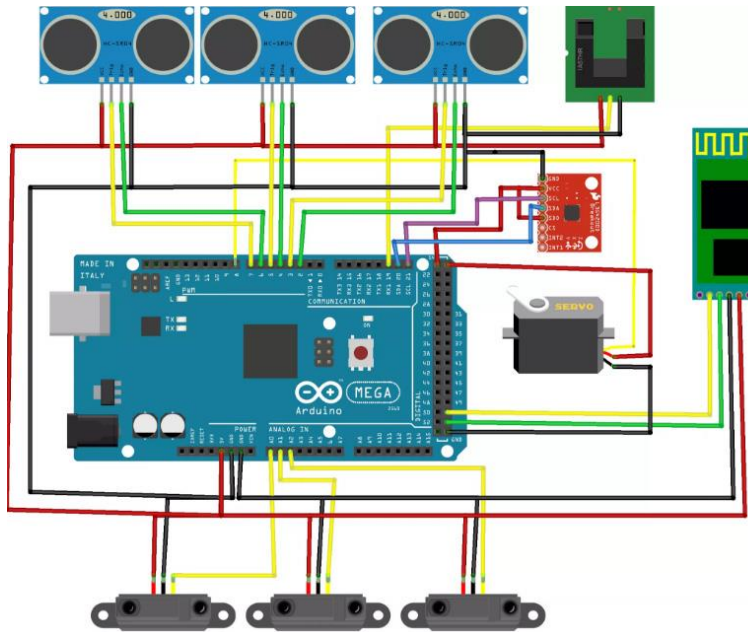

Figure 7. Working model for smart Parking.

Figure 6 shows the whole progression of the way vehicle will leave, how installment will occur and how space will be made accessible for next client.

Figure 7 given is the genuine working model of Smart Parking System which is executed using IoT development using various sensors, switch, Arduino, etc So far we have seen how to find a decent parking space. Be that as it may, vehicle prosperity is another critical test comparing to leaving the load up. There is 3 module using that vehicle security can be ensured. Arduino board consolidates different sorts of chip and smaller than normal controllers. It involves different straightforward and modernized information/yield pins. The board is given Universal consecutive vehicle (USB) that can be used to interface with the PC for stacking the code. Arduino supports C and C++ rules of code putting together. The interesting imprint sensor is associated with Arduino to look at the thumb impression. Basically, this sensor distinguishes snaps the photo of thumb and check the edges and valleys. If the customer is affirmed, by then the motor starts else it establishes a connection with the customer on his enrolled number saying that someone is endeavoring to get to your vehicle. Failing multiple undertakings, the message will be sent. The message will similarly consolidate the extension and longitude of the vehicle so customer can without a doubt follow his vehicle if there should be an event of emergency. Given Figure 8 is the flowchart of vehicle prosperity measure.

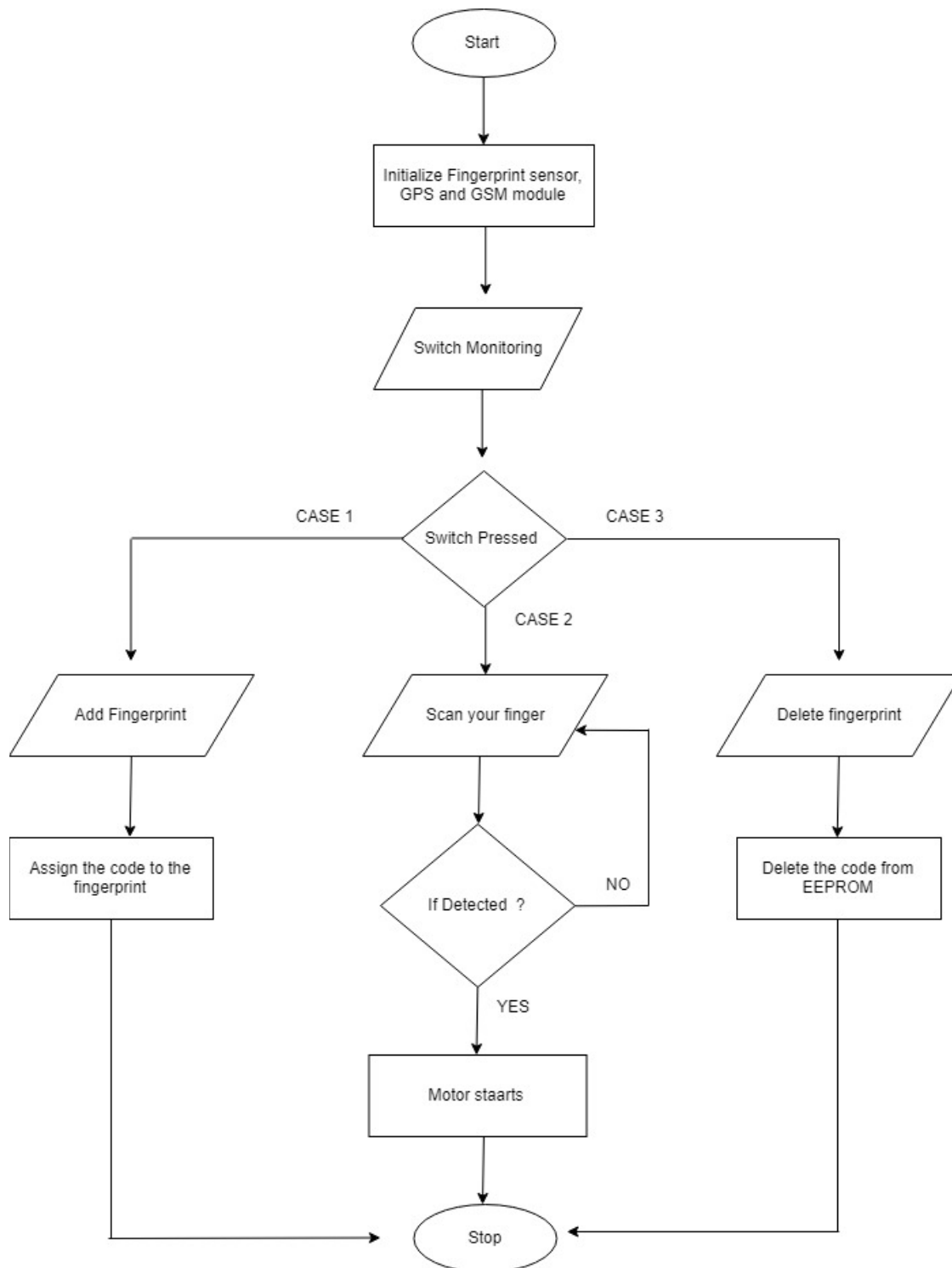

Figure 8. Flowchart for vehicle safety.

Here emerges one inquiry. Imagine a scenario in which the client's companion or relative needs to ride the vehicle. Actually unrealistic because a lone client's thumb is enrolled. The best piece of

this model is that beyond what one client can be enlisted at an alone time so different legitimate individuals can utilize the vehicle without any problem. The upside of this model is that it's moderately modest and can be fixed regardless of any car. The accompanying figures clarify the vehicle security flowchart.

4. CONCLUSION AND FURTHER SCOPE

In this investigation paper, using IoT advancement, we have proposed a model that can without a very remarkable stretch be impersonated consistently broadens. The middle objective of this paper is to contribute towards the vehicle business using IoT development. IOT maintain innovative considerations and gives hand crafted results. In the current circumstance, everybody utilizes smart gadgets. IoT is just not a well-known articulation, its moving and can be used in any endeavor. The above model offers the response to gridlock and vehicle security. Not simply this, taken vehicles can in like manner be found with no issue. The customer can without a doubt leave the vehicle inside few seconds and can loosen up about its safety efforts. There is a certain redesign that can be made, for instance, we can think about the android application so a customer can without a doubt check and book the halting opening. We can even use IoT development in safe driving by looking out for the road. This way we can make an undertaking to reduce the accidents.